





UPS OPERATING MANUAL





**Canon
UPS SYSTEM
U10K – 60Hz**

Important Notice

This document provides instructions about safety, installation and handling of the UPS.

-  It is necessary to read the manual completely before working on this equipment.
-  Turn On/Off UPS contact local service representative for instruction
-  Keep this manual near UPS for easy consultation!
-  All the settings of this UPS are made for Canon, changing settings is not allowed

Symbols

-  This symbol points out the instructions which are especially important.
-  This symbol points out the risk of electric shock if the following instruction is not obeyed.
-  This symbol points out the instructions, which may be resulted with the injury of the operator or damage of the equipment if not obeyed.

WARNING: This is a Class A-UPS Product. In a domestic environment, this product may cause radio interference, in wich case, the user may be required to take additional measures.

Content:

Important Notice	2
1 Safety	5
2 Installation	6
2.1 Transportation	6
2.2 Unpacking	6
2.3 Storage	7
2.3.1 Charging periodically	7
2.4 Placement	8
2.4.1 Environmental Requisites	8
2.4.2 Electrical Requisites	9
2.5 Connections	10
2.5.1.1 Protective Earth (Ground) Connections	11
2.5.1.2 Input connection	11
2.5.1.3 Battery Connection	12
2.5.1.4 Output Connection	12
2.5.2 Communication Interface Connections	12
3 Modes of Operation	13
3.1 Bypass Mode	14
3.2 Normal Mode	14
3.3 Battery Mode	15
4 Control and Monitoring	16
4.1 Front Panel	16
4.1.1 Keypad	16
4.1.2 Mimic Panel	17
4.1.3 Liquid Crystal Display (LCD) and User Menu	18
4.1.4 Buzzer	21
5 Operating Procedures	22
5.1 Commissioning	22
5.2 Decommissioning	22
5.3 Switching into manual by-pass during operation	23
5.4 Returning from manual bypass to UPS	23
5.5 Connection to a generator	23

6	Features and operating limits.....	24
6.1	Mains limits for normal operation	24
6.2	By-pass mains limits for bypass operation.....	24
6.3	Battery test	24
6.4	Overload behavior	25
6.5	Electronic short circuit protection	25
7	Communication	26
7.1	RS232 Communication	26
7.2	RS422 Communication	26
7.3	Digital Inputs (UPS OFF and GEN ON).....	27
7.4	Free Contact Communication.....	27
8	Maintenance	28
8.1	Battery fuses.....	28
8.2	Batteries	28
8.3	Fans	28
8.4	Capacitors.....	28
9	Troubleshooting	29
10	Technical Specifications	32

1 Safety



Information related to the safety of the UPS, loads and the user is summarized below. But the equipment should not be installed before reading the manual completely.



- ▶ The equipment may only be installed and commissioned by authorized technical persons.
- ▶ When the UPS is brought from a cold place to a warmer place, humidity of the air may condensate in it. In this case, wait for two hours before beginning with the installation.
- ▶ Even with no connections have been done, hazardous voltages may exist on connection terminals and inside the UPS. Do not touch these parts.
- ▶ Connect the PE ground connector before connecting any other cable.
- ▶ Do not put the battery fuses into the fuse holder before operating the equipment and seeing the “NORMAL” message on the LCD.
- ▶ The connections shall be made with cables of appropriate cross-section in order to prevent the risk of fire. All cables shall be of insulated type and shall not be laid out on the walking path of the persons.
- ▶ Do not expose UPS to rain or liquids in general. Do not introduce any solid objects.
- ▶ The equipment shall be operated in an environment, which is specified in “placement” section of this manual.
- ▶ Affix a label bearing the following expression, on the distribution panels feeding the UPS :
“Isolate the Uninterruptible Power Supply before working on this circuit”
- ▶ Do not plug the communication cables in or out during stormy weather.
- ▶ The equipment shall only be maintained and fixed by authorized technical persons.
- ▶ In case of an extraordinary situation (damaged cabin or connections, penetration of foreign materials into the cabin etc.) de-energize the UPS immediately and consult to the technical service.
- ▶ Replaced batteries must be disposed of at authorized waste disposal centers.
- ▶ Keep this manual near for easy consultation.
- ▶ The equipment shall be packed properly during transportation.
- ▶ The equipment is compliant with the European Community directives. Hence it is marked:



2 Installation

2.1 Transportation

The UPS must remain in a vertical position throughout the transportation. Make sure that the floor can support the weight of the system.

2.2 Unpacking

Equipment and batteries whose packages are damaged during transportation shall be inspected by a qualified technical person before starting with the installation.

The procedure is as following:

- ▶ Remove the bands and the protective packaging from the UPS.
- ▶ Use suitable equipment to remove the UPS from the pallet.
- ▶ Mount the cabinet parts supplied with the UPS after positioning and connecting the UPS.



The equipment shall be packed properly during transportation. Therefore it is recommended to keep the original package for future need.

Check if the following are provided with the equipment

- ▶ Key of the cabin door
- ▶ Battery fuses (three pieces)
- ▶ Test report
- ▶ Installation procedure
- ▶ UPS Input cable
- ▶ UPS Output cable

2.3 Storage

Recommended storage temperature, humidity and altitude values are listed on the “Technical specifications” section.

If the batteries will be stored for longer than 2 months, they shall be charged periodically. Charge period depends on the storage temperature. The relationship is as shown below:

- ▶ Every 9 months if the temperature is below 20 °C,
- ▶ Every 6 months if the temperature is between 20 °C and 30 °C,
- ▶ Every 3 months if the temperature is between 30 °C and 40 °C,
- ▶ Every 2 months if the temperature is over 40 °C

2.3.1 Charging periodically

The batteries need to be charged every 4 months periodically, when the UPS is stored for a longer time. When the batteries are not charged within 6 months, the batteries will be permanently damaged. A charge cable 4P+E 4mm² is already connected to the UPS by first delivery. At the end of this cable there is a CEE-form connector which fits in the connector of the charger type: UPS charger, UPS types: U6000-P0620D + U10K Version 1.1.

- ▶ To start charging the batteries of the UPS, open the front panel of the wooden crate
- ▶ Connect the 4P+E (blue CEE-Form) connector to the UPS charger Version 1.1
- ▶ Start the charger to power the output of the charger, see manual charger
- ▶ Follow the commissioning procedure of the UPS, paragraph 5.1 of this manual
- ▶ Charge the batteries at least 4 hours
- ▶ After charging please follow the decommissioning procedure, paragraph 5.2 of this manual



Use the charger cable only for charging, do not place a load at the output of the UPS

2.4 Placement

2.4.1 Environmental Requisites

This product meets the safety requirements for devices to be operated in restricted access locations according to EN 60950-1 safety standard, which states that the owner should guarantee the following:

- ▶ Access to the equipment can only be gained by service persons or by users who have been instructed about the reasons for the restrictions applied to the location and about any precautions that shall be taken and,
- ▶ Access is through the use of a tool or lock and key, or other means of security and is controlled by the authority responsible for the location.

Recommended operating temperature, humidity and altitude values are listed on the “Technical specifications” section. Air conditioning may be required to provide these values.

Other requisites are:

- ▶ The equipment and the batteries shall not be exposed to direct sunlight or placed near to a heat source.
- ▶ Do not expose UPS to rain or liquids in general. Do not introduce any solid objects.
- ▶ Avoid dusty environments or areas where dust of conductive or corrosive materials is present.
- ▶ Air outlets of the UPS are on sides, front and back. Leave at least 100 mm at the front and both sides and 100 mm at the back for maintenance and ventilation.

Side requirements

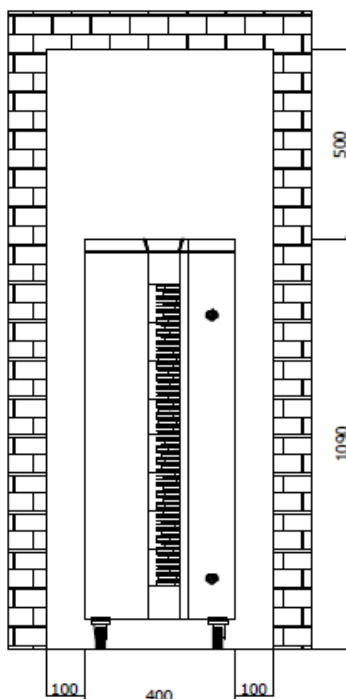

Front view

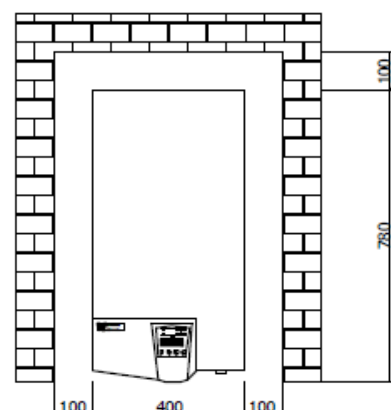

Top View

2.4.2 Electrical Requisites

The installation must comply with national installation regulations.

The electrical distribution panels for the mains and separated by-pass mains inputs must have a protection and disconnection system. Disconnection devices used in these panels shall disconnect all line conductors and the neutral conductor simultaneously. The following table shows the recommended size of the mains and separate by-pass mains input protection devices (thermal, magnetic and differential) and the cable cross-sections for the linear loads.

UPS	Input thermal protection	Bypass mains input thermal protection	Input cable cross-section	Bypass mains input cable cross-section	Battery cable cross-section	Leakage current protection*
10 kVA (3Ph output)	40 A	40 A	10 mm ²	10 mm ²	10 mm ²	30 mA

Input magnetic protection devices shall have D characteristic.

*Load leakage currents are added to those generated by the UPS. If loads with high leakage currents are present, adjust this value accordingly. It is recommended to adjust the protective device after measuring the total leakage current with the UPS installed and operational with the intended load.

During transitory phases (power failure, return and voltage fluctuations) short leakage current peaks may occur. Make sure that the protection is not activated in such cases.



If the loads have a nonlinear characteristic, the current on the mains input, separate by-pass mains input and output neutral conductors may have a value that is 1.5-2 times the phase value during operation. In this case, size the neutral cables and the input/output protection adequately.



According to EN 62040-1-2, the user shall place a warning label on the input distribution panel and the other primary power isolators, in order to prevent the risk of electric shock caused by a fault voltage on the UPS. The label shall carry the following wording:

Isolate uninterruptible power supply before working on this circuit

2.5 Connections

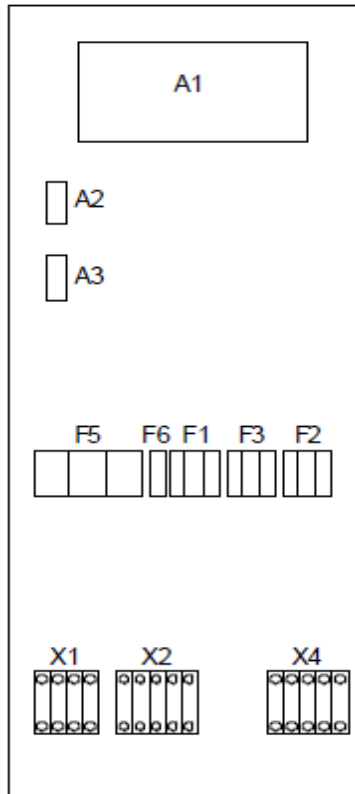

Connections shall be done by authorized technical staff only.



When the UPS is brought from a cold place to a warmer place, humidity of the air may condensate in it. In this case, wait for two hours before beginning with the installation.

Layout of the connection terminals and boards are shown below:

A1: Communication interface board

A2: Service connector rectifier

A3: Service connector inverter

F1: Input circuit breaker

F2: Output circuit breaker

F3: Manual by-pass circuit breaker

F5: Battery fuses

F6: Inrush circuit breaker

X1: Battery terminals

X2: Input mains terminals

X4: Output terminals



Devices with internal batteries may have dangerous voltages on the battery terminals

The power screw terminals are located on the lower front side of the UPS. Terminal details for a 3ph output ups are shown separately in the below figures. Refer to the names of each terminal to identify it during connection:

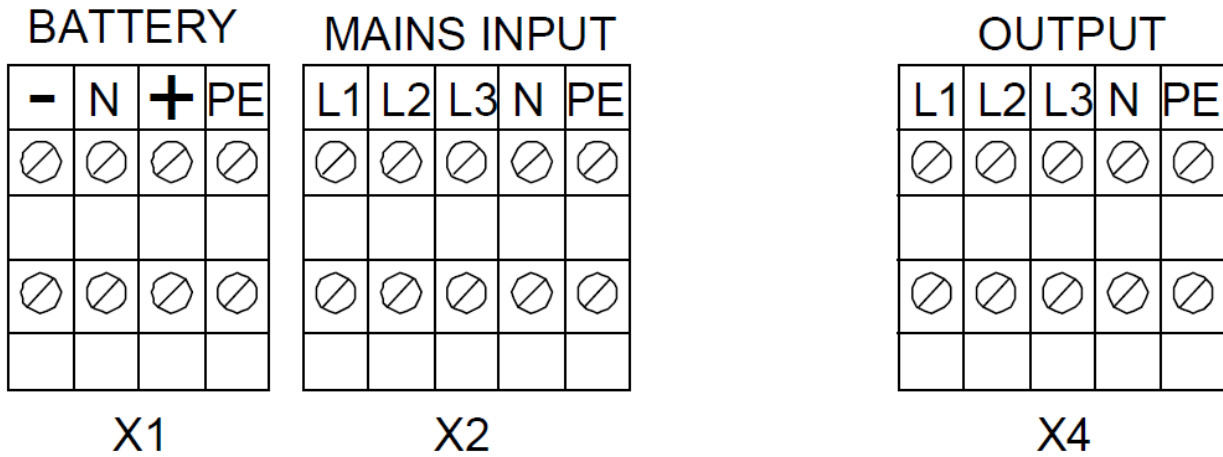

Cables shall be passed through the hole under the connection terminals. Make sure that all circuit breakers are “OFF”/”0” before starting with the installation. Connections shall be done with the order below.

2.5.1.1 Protective Earth (Ground) Connections



The device shall be earthed for a safe and reliable operation. Connect the PE ground connectors before connecting any other cable

Input protective earth connection terminal (PE) of the UPS shall be connected to ground with a low impedance connection.

PE terminals of the loads shall be connected to output protective earth terminal of the UPS.

If there is an external battery cabin present, it shall be grounded via battery protective earth terminal of the UPS.

2.5.1.2 Input connection



Bring the circuit breaker on the distribution panel to “OFF” or “0” position before making the connections

Connect the phases to input (X2) L1, L2 and L3 terminals. A definite phase sequence is needed for the UPS for correct operation. If you encounter “IN SEQ FLR” alarm at start up, decommissioning UPS, make the protection devices on the input distribution panels “0”/”OFF” and interchange any two phase cable of the input.

2.5.1.3 Battery Connection



Do not put the battery fuses into the fuse holder (F5) before operating the equipment and seeing the “NORMAL” message on the LCD.



Devices with internal batteries may have dangerous voltages on the battery terminals



Danger of explosion and fire if the batteries of the wrong type are used.

2.5.1.4 Output Connection



To enable the short circuit protection feature of the UPS, each load shall be fed over a separate circuit breaker chosen according to the load current. This may provide quick disconnection of the short circuited load and operation continuity of the other loads. To obtain maximum protection, the rating of each individual load circuit breaker shall have the minimum value, which is enough to carry the full load current continuously.



Rated apparent and active power of the loads shall be less than the UPS power ratings.

Connect the loads to output (X4) L1, L2 and L3 terminals.

2.5.2 Communication Interface Connections

Related information is given in “communication” section.

3 Modes of Operation

There are three operation modes, which differ in the path of the energy flow. UPS block diagrams and the energy flow path in each operation mode is shown below:

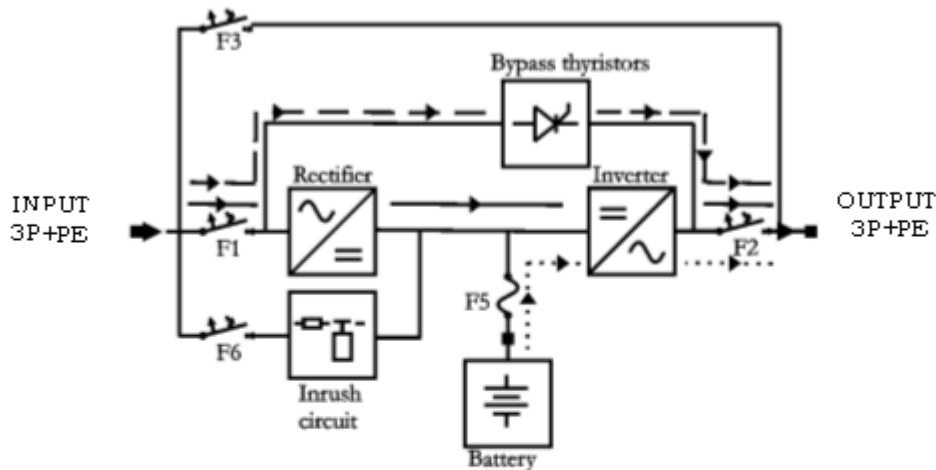

Block diagram without separate manual bypass input

— Normal - - - Bypass mode Battery mode

When UPS has no separate bypass mains input, bypass line is also fed from the mains input. So, if such a device is in question, mains input shall be comprehended when the bypass mains input is referred in the following sections of the manual.

UPS behavior at the start-up is different from the usual operation. The UPS can only operate in bypass mode during start-up. So, in order for the UPS to start-up, frequency/waveform/rms value of the bypass mains voltage shall be in acceptable limits and bypass shall be enabled.

After start-up, the following applies:

Operation mode depends on the priority, inverter, rectifier and bypass preferences made by the user and mains, separate by-pass mains and battery voltages.

Priority and inverter, rectifier and bypass preferences can be set by using the COMMANDS and extra commands (EXTCMNDS) menus.

If operation in any of these modes is impossible, output voltage will not be present. In this case, loads will not be fed, and "VSECFLR" message is shown on the LCD instead of operation mode.

Summary:

The UPS by-pass and mains line is fed from the mains input (X2). UPS behavior at the start-up is as follows:

1. By-pass on output fed from by-pass.
2. The rectifier, inverter and charger will start up if voltage and frequency are within limits, inverter synchronizing with by-pass. After completion by-pass will switch off and batteries will be charged.
3. Display shows normal.

3.1 Bypass Mode

Devices without separate bypass mains input, absorb energy from the mains. Loads are fed via static bypass line. Output voltage has the same amplitude, frequency and waveform as the input voltage. Current drawn by the loads are only limited by the thermal/magnetic switches over the energy flow path. Voltage, frequency and waveform of the bypass supply shall be in their tolerance limits, and bypass shall be enabled for the UPS to operate in this mode.

When the upper provisions are met, the UPS works in bypass mode in the following conditions:

- ▶ During the start-up
- ▶ If the bypass priority is selected
- ▶ If the inverter is disabled or blocked
- ▶ In case of a prolonged overload

You can save energy by selecting the bypass priority. Efficiency in bypass mode is higher than the efficiency in normal mode. If the bypass priority is selected, the UPS will operate in bypass mode whenever the frequency/waveform/rms value of bypass mains voltage is in their tolerance limits. If the bypass voltage goes beyond these limits, the UPS switches into normal operation.



Bypass mode doesn't provide perfect stability in frequency/waveform/rms value of the output voltage like in normal mode. Thus, the use of this mode should be carefully executed according to the level of protection required by the application.



Bypass mode doesn't provide electronic short circuit protection like in normal mode. If a short circuit or occurs on the output during bypass operation, the thermal/magnetic protection will act and all loads will be de-energized.



Prolonged overloads may cause the thermal/magnetic protection act. In this case, all loads will be de-energized.

3.2 Normal Mode

Energy is drawn from the mains input. Loads are fed via the rectifier and the inverter. The AC voltage at the input is converted to a DC voltage by the rectifier. The inverter converts this DC voltage to an AC voltage with a stable sinusoidal waveform, amplitude and frequency. Output voltage is sinusoidal and has a regulated amplitude and frequency. It is independent from the input voltage. The inverter is synchronized in frequency with the bypass mains input to enable load transfer to the bypass supply without any interruption, in case of an overload or inverter failure.

Voltage and frequency of the mains input shall be in their tolerance limits, and both the rectifier and the inverter shall be enabled for the UPS to operate in this mode.

When the upper provisions are met, the UPS works in normal mode in the following conditions:

- ▶ If the inverter priority is selected.
- ▶ If the bypass priority is selected but bypass is disabled or frequency/waveform/rms value of bypass mains voltage is not in acceptable limits.

3.3 Battery Mode

Energy is drawn from the batteries. Loads are fed via the inverter. Output voltage is sinusoidal and has a regulated amplitude and frequency. It is independent from the battery voltage.

Battery voltage shall be in acceptable limits and the inverter shall be enabled for the UPS to operate in this mode. When the upper provisions are met, the UPS works in battery mode in the following conditions:

- ▶ If rectifier is disabled.
- ▶ If the rectifier is disabled or frequency/waveform/rms value of mains voltage is not in acceptable limits.

4 Control and Monitoring

4.1 Front Panel



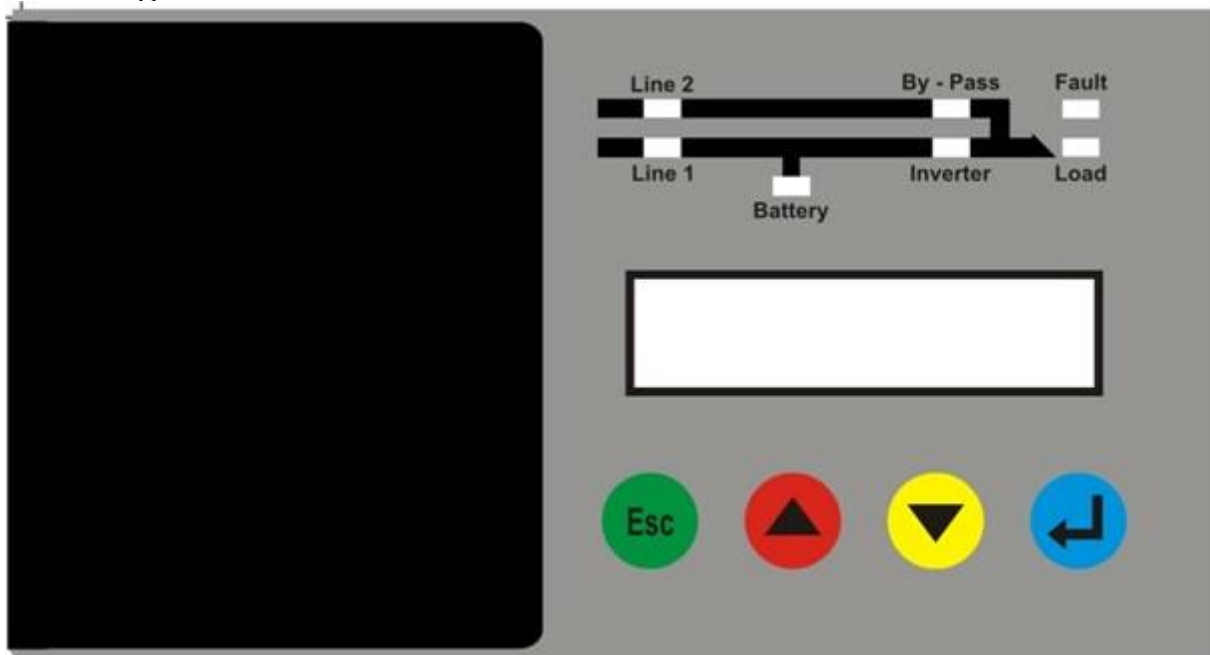

The front panel located on the upper part of the UPS informs the user about operating status, alarm conditions and measurements. It also provides access to controls and configuration parameters.

Front panel shown below consists of three parts. As mimic panel provides basic information about the energy flow path and existing alarms, LCD (liquid crystal display) offers detailed information and provides access to controls. Keypad enables the user to move in the menu and to make selections.



4.1.1 Keypad

Functions of the buttons are given below:

BUTTON	SYMBOL	DEFINITION
ESC		Exit from the current menu
UP		Scrolls the available menus/values upwards. It increases the value each time it is pushed when changing a parameter.
DOWN		Scrolls the available menus/values downwards. It decreases the value each time it is pushed when changing a parameter.
ENTER		Enters the menu displayed on the screen. It makes selections or confirms the choice/changes made.

4.1.2 Mimic Panel

Mimic panel is a diagram, which shows the path of energy flow in the UPS by means of several LED's. Definitions of LED states are shown below:

LED's			
ID	COLOR	DEFINITION	STATE
Line 1	Green	Input mains voltage is OK and rectifier is active	Steady
		Input mains voltage is OK and rectifier is inactive	Flashing
		Input mains voltage is very close to its upper/lower limit and rectifier is active	
		Input mains voltage is not OK	Off
Line 2	Green	Bypass voltage is OK	Steady
		Bypass voltage is not OK and output voltage is synchronized to the bypass voltage	Flashing
		Bypass mains voltage is not OK and output voltage is not synchronized to the bypass voltage	Off
Battery	Red	Battery mode is active and battery voltage is OK	Steady
		UPS is performing battery test and battery voltage is OK	
		Battery mode is active and battery voltage is close to its lower limit (energy available in the battery is about to be depleted)	Flashing
		Battery test is active and battery voltage is close to its lower limit (energy available in the battery is about to be depleted)	
		Rectifier is active and able to supply whole power required by the inverter	Off
Inverter	Green	Load is fed via inverter	Steady
		Inverter is not active	Off
Load	Green	Load is powered	Steady
		Load is powered but UPS is overloaded	Flashing
		Output voltage is not OK	Off
Bypass	Yellow	Load is fed via static bypass line	Steady
		Bypass is not active	Off
Fault	Red	No alarms	Off
		A minor alarm is present	Flashing
		A major alarm is present	Steady

4.1.3 Liquid Crystal Display (LCD) and User Menu

LCD provides detailed information about device status, alarms and measurements. It also enables the operator to manage the UPS. All information, commands and configuration parameters are given in a menu, which has the following structure:

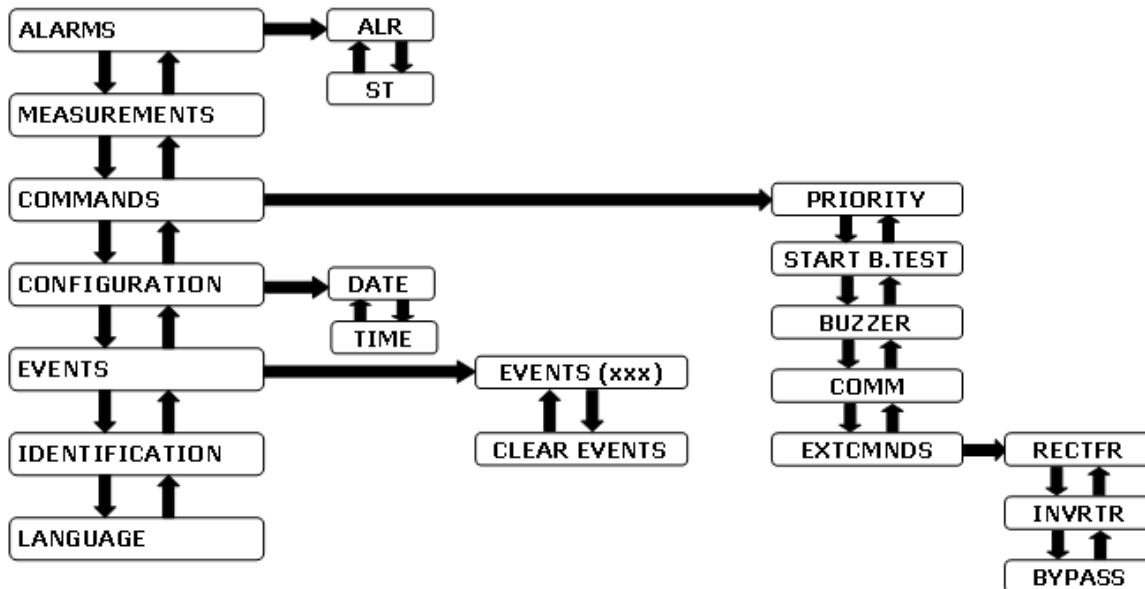

LCD consists of two lines and has the following structure:

“OPERATING MODE” or “VSECFLR”
“MENU or PARAMETER NAME”

If there is no voltage on the output, VSECFLR message is displayed on the upper line.
Operation mode parameter is one of the notations below:

OPERATING MODE NOTATIONS	
NORMAL	Normal mode
BYPASS	Bypass mode
BATT	Battery mode

Menu and parameter descriptions are given below:

ALARMS MENU	
ALR = “XXXXXXXXXXXXXX”	12 digit service codes.
ST = “XXXX-XXXXXXXX”	Note these numbers before referring technical service.

Alarm codes and names can be seen by entering the ALR submenu.

CODE	NAME	DEFINITION
A01	BYP BADSHAPE	Bypass mains voltage is different than the inverter reference signal (e.g. its frequency is beyond synchronization limits or it has a total harmonic distortion > %10)
A02	BYP VOL HIGH	Bypass mains voltage is higher than its upper limit
A03	BYP VOL LOW	Bypass mains voltage is lower higher than its lower limit
A06	BYP SYN FAIL	Frequency of bypass mains voltage is beyond the frequency range for bypass operation or bypass mains voltage is very low
A07	BYP SEQ FAIL	Phase sequence of bypass mains voltages is not OK
A08	MNBYP SW ON	Manual bypass switch is "ON"
A09	INV TMP HIGH	Inverter block temperature is very high
A10	OUT OVERLOAD	RMS current drawn from any of the output lines exceeds its nominal value
A11	BYP ACT	Bypass is activated.
A12	INV NOT ACT	Inverter is not started due to a fault
A13	INV BLCK	Inverter operation is automatically stopped due to a fault
A14	VSEC NOT OK	Output voltage is beyond its limits
A15	MASTER T-OUT	This alarm is observed when information flow from master ups is interrupted
A16	CABLE UNPLUG	Parallel Communication cable is unplugged or damaged
A17	INP VOL HIGH	Input line/neutral voltage is higher than its upper limit
A18	INP VOL LOW	Input line/neutral voltage is lower than its lower limit
A21	INP SYN FAIL	Frequency of mains voltage is beyond the frequency range for normal operation or mains voltage is very low
A22	INP SEQ FAIL	Phase sequence of input mains voltages is not OK
A23	REC TMP HIGH	Rectifier block temperature is very high
A24	REC OVERLOAD	RMS current drawn from any of the input lines exceeds its nominal value
A25	VDC HIGH	DC bus voltages is higher than its upper limit
A26	VDC LOW	DC bus voltages is lower than its lower limit may mean that the battery is empty during battery operation
A27	REC NOT ACT	Rectifier is not started due to a fault
A28	REC BLCK	Rectifier operation is automatically stopped due to a fault
A30	TESTING BATT	Battery test is performed
A31	REDUND. LOST	It appears in case $Load \% \times (N+1) / N > 100$, for more information refer to page:28
A32	N FAULT	Depending on N description (n+1, n+2...), this alarm is observed when the qty of ups in the systems decreases below N value
A33	REC OFF	Rectifier is inactive
A34	INV OFF	Inverter is inactive
A35	BYP OFF	Bypass is inactive
A36	BYP PRI HIGH	Priority is Bypass
A37	BATT DISCHAR	Batteries are discharging after a mains failure
A38	VDC NOT OK	DC bus voltage is out of its normal range
A39	T-AMP HIGH	Ambient temperature exceeds its upper limit
A40	GENSET ON	Generator friendly operation is activated
A41	EMG STOP ON	Emergency stop is activated
A42	MINOR ALR	Minor Alarm
A43	MAJOR ALR	Major Alarm
A44	BATT TS FAIL	Batteries failed in the battery test
A45	BATT CR OPEN	Battery Circuit Breaker is open
A47	INV RX T-OUT	Communication between the inverter and the front panel is lost
A48	REC RX T-OUT	Communication between the rectifier and the front panel is lost

All alarms except VSEC NOT OK are minor.

MEASUREMENTS MENU		
MEASUREMENT		DEFINITION
LD	= XXX,XXX,XXX %	Ratio of the actual inverter active power of each line to its nominal value
Vsc	= XXX,XXX,XXX V	Output line/neutral voltages
Isc	= XXX,XXX,XXX A	Output line currents
Fo	= XX.X Hz	Frequency of output line/neutral voltages
Vby	= XXX,XXX,XXX V	Bypass line/neutral voltages
Vin	= XXX,XXX,XXX V	Input line/neutral voltages
Iin	= XXX,XXX,XXX A	Rectifier Input Current
Fin	= XX.X Hz	Frequency of input line/neutral voltages
Vdc	= XXX,XXX V	Positive and negative DC bus voltages
Vbat	= XXX,XXX V	Positive and negative battery branch voltages
Ibat	= ±XXX,±XXX A	Positive and negative battery branch currents Positive during charge, negative during discharge
Tbat	= XXX °C	Ambient temperature

COMMANDS MENU		
PRIORITY	= INVRTR/BYPASS	Selects the priority of normal and bypass operation modes Push ENTER to switch between INVRTR and BYPASS
START B. TEST		Push ENTER to start battery test
BUZZER	= ENBLD/DSBLD	Enable or disable the buzzer Push ENTER to switch between ENBLD and DSBLD
COMM	= RS232/RS422	Push ENTER to switch between RS232/RS422 communication
EXTCMNDNS		Push ENTER 3 times to enter this submenu

EXTRA COMMANDS SUBMENU		
RECTFR	= ENBLD/DSBLD	Enable or disable operation of the rectifier block Push ENTER to switch between ENBLD and DSBLD
	= BLCKD*1	Can be seen only when the rectifier is blocked Push ENTER to remove the blockage and enable the rectifier
INVRTR	= ENBLD/DSBLD	Enable or disable the operation of the inverter block Push ENTER to switch between ENBLD and DSBLD
	= BLCKD*1	Can be seen only when the inverter is blocked Push ENTER to remove the blockage and enable the inverter
BYPASS	= ENBLD/DSBLD	Enable or disable the operation of the bypass thyristors Push ENTER to switch between ENBLD and DSBLD

*1 The UPS hinders the operation of the rectifier and inverter blocks in case of a failure.

CONFIGURATION MENU	
DATE = "XX-XX-XXXX"	Shows system date in dd-mm-yyyy format Push ENTER to switch between day, month, year, hour, minute and second. Then, use arrows to configure
TIME = "XX-XX-XX"	Shows system time in hh-mm-ss format Use date submenu to set time

EVENTS MENU	
EVENTS (xxx)	Shows last 380 events (alarms) of system. (xxx) shows events count. To look event details, you must press ENTER key in current position and use UP/DOWN keys.
CLEAR EVENTS	Clears all events stored in eeprom after verification of clear process.

EVENTS (xxx) SUB MENU	
YYY : AAAAAAAAAAAAA	“YYY” Shows order number of event and “AAAAA-A” shows event description. (For events descriptions see ALARM DEFINITIONS on page 17). Events stored in eeprom using FIFO method. Order number of last occurred event is 001. To look event details, you must press ENTER key in current position and use UP/DOWN keys.
DATE = XX/XX/XXXX	Displays date of event occurring.
TIME = XX:XX:XX	Displays time of event occurring.
A:XXXX-XXXX-XXXX	Displays alarm status when event is occurred.
ST=XXXX-XXXXXXXXXX	Displays status string when event is occurred.

IDENTIFICATION MENU	
"X/X XXX kVA"	Shows number of input/output phases and output nominal apparent power
FW = "XX"	Shows firmware version

4.1.4 Buzzer

Buzzer warns the user about the present alarms. It can be disabled by using the commands menu

BUZZER	
STATE	DEFINITION
Off	No alarms
Discontinuous	A minor alarm is present
Steady	A major alarm is present

5 Operating Procedures

This chapter defines the operating procedures to be followed to activate, deactivate and manage the UPS. The instructions shall be applied with the sequence, in which they are written.

5.1 Commissioning

-  Do not put the fuses of the battery circuit breaker inside the breaker until mentioned in this document. Accidentally switching in the battery circuit breaker on the wrong moment it will blow the fuses!

Make the connections according to the installation section.
 Switch the circuit breaker on the POWER Distributor (CETF) “ON” / “I”.
 Bring the inrush circuit breaker (F6) to “ON” / “I” position.
 Bring the input circuit breaker (F1) to “ON” / “I” position.
 Wait for the LCD to start up. Set the date and time.
 See the “NORMAL” message on the LCD.
 Bring the output circuit breaker (F2) to “ON” / “I” Position.
 Put the fuses in the battery circuit breaker.
 Bring the battery circuit breaker (F5) to “ON” / “I” position.

-  The UPS starts up in bypass mode and automatically switches to normal mode. “NORMAL” message will not be displayed, until the UPS switches to normal mode. Frequency/waveform/rms value of the bypass mains voltage shall be in acceptable limits and bypass shall be enabled for the UPS to start-up. Voltage and frequency of the mains input shall be in their tolerance limits, and both the rectifier and the inverter shall be enabled for the UPS to operate in normal mode.

5.2 Decommissioning

Bring the output circuit breaker (F2) to “OFF”/”0” position.
 Bring the input, inrush and manual by-pass circuit breakers (F1, F6 and F3) to “OFF”/”0” position.
 Bring the battery circuit breaker (F5) to “OFF”/”0” position.
 Bring the circuit breaker of the external battery cabinets to “OFF”/”0” position.
 Switch the circuit breaker on the input Power Distributor (CETF) “OFF” / “0”.

-  In the event of an extended period of UPS inactivity, the batteries must be charged periodically in order to prolong battery life. The charge period, which depends on the temperature, is given in the “storage” section of the manual.

5.3 Switching into manual by-pass during operation

Manual by-pass enables the user to isolate the electronic circuitry of the UPS from the mains and the load without interrupting the load operation by connecting the loads directly to the bypass supply. This feature is useful while performing maintenance or service and shall only be executed by authorized technical service personnel.



Maintenance and service may only be performed by authorized technical personnel

Bring the manual bypass circuit breaker (F3) to “ON”/ “I” position.

Make sure that the UPS switches into bypass mode (see “BYPASS” message on the LCD). Voltage, frequency and waveform of the bypass mains shall be in limits, and bypass shall be enabled for the UPS to operate in bypass mode.

Bring the input and inrush circuit breakers (F1 and F6) to “OFF”/”0” position.

Bring the output and battery circuit breakers (F2 and F5) to “OFF”/”0” position.

LCD and buzzer will stop operation in a few minutes.



During manual bypass operation, loads are fed directly from bypass mains. Therefore no protection against mains disturbances or interruptions is present.



Although all switches except F3 is “OFF” during manual bypass operation, hazardous voltages are present on the terminals, EMC filters and measurement circuits.

5.4 Returning from manual bypass to UPS

Bring the output circuit breaker (F2) to “ON”/”I” position.

Bring the input and inrush circuit breakers (F1 and F6) to “ON”/ “I” position.

Bring the manual bypass circuit breaker (F3) “OFF”/”0” position.

See the “NORMAL” message on the LCD.

Bring the battery circuit breaker (F5) to “ON”/ “I” position.

5.5 Connection to a generator

If the input power is supplied by a generator, set the digital input “GEN ON” high. This ensures generator friendly operation by smoothing the increment of the current drawn from the generator, during transition from battery mode to normal mode.

When this is done, “GEN ON” alarm will be shown. Connection details are given in the “communication” section.

6 Features and operating limits

6.1 Mains limits for normal operation

Frequency and rms value of the mains input voltage has to be between acceptable limits for the UPS to operate in normal mode.

Lower limit of the voltage depends on how much the UPS is loaded and it decreases as the load decreases until it reaches 75 V line-line.

Frequency lower and upper limits and voltage upper limit are fixed.

Voltage and frequency ranges for normal operation are given in the “technical specifications” section of the manual.

This feature lessens the need to use the batteries. Thus, it increases the battery life and continuity of the load power.

6.2 By-pass mains limits for bypass operation

Frequency, rms value and total harmonic distortion of the bypass mains input voltage has to be between acceptable limits for the UPS to operate in bypass mode.

Different rms voltage upper and lower limits are present for the return from another operation mode to bypass mode. This provides hysteresis and ensures that the device does not change operation mode very often when the bypass mains rms voltage is close to one of the limits.

Bypass mains limits are software parameters. They can be changed upon request.

6.3 Battery test

This feature enables the user to obtain information about the battery condition. If the batteries have approached end of their lives, batteries fail.

Battery life depends on several parameters like the number of charge-discharge cycles, discharge depth and ambient temperature. Battery life greatly decreases as the ambient temperature increases. Therefore it is recommended to keep the ambient temperature about 20 °C.

To perform a battery test, enter “START B. TEST” in the COMMANDS menu and wait. The UPS will switch into battery mode, when the test has started. After about ten seconds, UPS will return to the operation mode before the test. If the batteries pass the test, no alarm will be shown.

If the batteries fail, you’ll receive BATT FAILED message under the ALR submenu. In this case, make sure that the battery circuit breaker is “ON”/”I”, charge the batteries for minimum 10 hours and repeat the test. If the alarm persists, consult technical service for replacement.



Make sure that the batteries are fully charged and battery circuit breaker is “ON”/”I” before starting battery test. Otherwise, the batteries will fail even if they are in good condition.

BATT FAILED message will not disappear until another successful test is performed.

6.4 Overload behavior

While operating in normal or battery mode, the UPS can feed overloads for a limited duration which is given in the “technical specifications” section. After that duration, UPS automatically switches into bypass mode, if the bypass is enabled and frequency/waveform/rms value of the bypass mains voltage is acceptable. If the overload situation continues in the bypass operation, thermal/magnetic protection devices may activate and protect the circuit. In this case, all loads on the output will be de-energized.

 Make sure that the UPS is not overloaded to provide a higher quality supply to the loads.

6.5 Electronic short circuit protection

The UPS attempts to force the thermal/magnetic protection devices between the output terminals and the short circuited load to open, by supplying current to the short circuited load for a limited duration. The UPS shall be working in battery or normal mode, for this feature to work.

 To enable the short circuit protection feature of the UPS, each load shall be fed over a separate circuit breaker chosen according to the load current. This may provide quick disconnection of the short circuited load and operation continuity of the other loads. To obtain maximum protection, the rating of each individual load circuit breaker shall have the minimum value, which is enough to carry the full load current continuously.

If the protection device fails to open the circuit in a limited time, the UPS stops feeding current to the output. “VSECFLR” message is shown on the upper left of the LCD.

7 Communication

All related terminals are on the communication interface board (A1). Connector layout is as following:

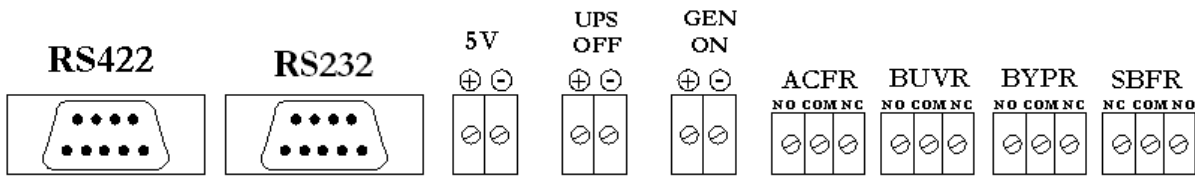

7.1 RS232 Communication

DSUB-9 female connector with the following pin layout shall be used on the UPS side of the connection cable. Pin layout is given below:

RS232 PIN LAYOUT		
Pin #	Signal Name	Signal Description
2	RX	Receive data
3	TX	Transmit data
5	GND	Signal ground

RS232 cable shall be shielded and shorter than 15 m.

Only one of the RS232/RS422 communications can be activated at one time. The selection between RS232 and RS422 communications can be done by setting the COMM parameter in COMMANDS menu, as desired.

7.2 RS422 Communication

DSUB-9 male connector with the following pin layout shall be used on the UPS side of the connection cable. Pin layout is given below:

RS422 PIN LAYOUT		
Pin #	Signal Name	Signal Description
6	A	Receive signal pair
5	B	
1	Z	Transmit signal pair
9	Y	
4	GND	Signal ground

RS422 cable shall be shielded and shorter than 100 m.

Only one of the RS232/RS422 communications can be activated at one time. The selection between RS232 and RS422 communications can be done by setting the COMM parameter in COMMANDS menu, as desired.

7.3 Digital Inputs (UPS OFF and GEN ON)

Voltage to be applied to the digital inputs is 5V DC. Maximum current drawn by each input is 1 mA. 5V DC supply provided on the communication interface board can be used to supply both digital inputs.

 Pay attention to the polarity of the voltages applied to the digital input terminals.

Input	Function
UPS OFF	If the UPS OFF input is set high by applying 5V DC voltage on the related terminals, UPS stops generating the output voltage and stops feeding the load. When the voltage on the digital input is removed, the UPS starts up according to the normal procedure.
GEN ON	If the GEN ON input is set high by applying 5V DC voltage on the related terminals, UPS smoothly increases the current drawn from the generator during transitions from battery mode to normal mode.

7.4 Free Contact Communication

Free contact relay connection cables shall have a cross-section of 1.5 mm².



Maximum voltage to be applied to the relay contacts is 42V AC rms (sinus) or 60 Vdc. Maximum contact current depends on the applied voltage and the load characteristic. Both maximum voltage and maximum contact current corresponding to the applied voltage shall not be exceeded.

Maximum allowed resistive contact currents for several voltages are given on the table below:

Applied voltage	Maximum contact current for resistive load
Up to 42 V AC	16 A
Up to 20 V DC	16 A
30 V DC	6 A
40 V DC	2 A
50 V DC	1 A
60 V DC	0.8 A

Each relay has both a normally open (NO) and a normally closed (NC) contact. One end of these contacts is common. Normal states of the relay contacts are shown on the figure at the beginning of the “communications” section.

Relay functions are described below:

Relay	Function
ACFR (AC failure relay)	Contacts change position if the rms value or frequency of the mains voltage is beyond their limits.
BYPR (Bypass relay)	Contacts change position if the UPS is working in the bypass mode
BUVR (Battery under voltage relay)	Contacts change position if the battery voltages are critically low to feed the load and the load power is about to be interrupted
SBFR (secure bus failure relay)	Contacts change position, if the output voltage disappears

8 Maintenance

Batteries, fans and capacitors shall be replaced at the end of their lives.



Hazardous voltage and high temperature metal parts inside even if the UPS is disconnected. Contact may cause electric shock and burns. All operations except replacing battery fuses shall be carried out by the authorized technical personnel only.



Some parts inside the UPS (terminals, EMC filters and measurement circuits) are still energized during maintenance bypass operation. In order to de-energize all UPS parts, circuit breakers on mains and bypass mains distribution panels feeding the UPS and circuit breakers on external battery cabinet shall be brought to “OFF/0” position. Internal batteries shall also be isolated from the system.

8.1 Battery fuses

Bringing the battery circuit breaker to “I”/“ON” position before seeing “NORMAL” message on the LCD may cause battery fuses to blow out.



Battery fuses shall only be replaced with Gould 22x58 aR 660V ultra fast fuse of same rating or equivalent.

8.2 Batteries

Battery life strongly depends on the ambient temperature. There are also other factors like the number of charge-discharge cycles and discharge depth.

Battery life is between 3-10 years if the ambient temperature is between 10 – 20 °C. Performing battery test can provide you information about battery condition. (See “battery test” section for more information on battery test)



Danger of explosion and fire if the batteries of the wrong type or number are used.



Do not dispose of batteries in a fire. The batteries may explode. Do not open or mutilate batteries. Released electrolyte is harmful to the skin and eyes. It may be toxic.

8.3 Fans

The life of fans used to cool the power circuits depends on the usage and environmental conditions. Preventive replacement by authorized technical personnel every four years is recommended.

8.4 Capacitors

The life of the electrolytic capacitors on the DC bus and the capacitors used for output and input filtering purposes depends on the usage and environmental conditions.

Preventive replacement by authorized technical personnel every five years is recommended.

9 Troubleshooting

This section gives information about the procedures which shall be performed in case of abnormal operation. If you fail to fix the problem consult authorized technical service with the following information:

- ▶ Model and serial number of the UPS, which can be found on the nameplate on the rear of the UPS. This information is also available in the test report provided with the UPS.
- ▶ ALR and ST codes in the ALARMS menu



Hazardous voltage and high temperature metal parts inside even if the UPS is disconnected. Contact may cause electric shock and burns. This unit is to be served by authorized technical personnel only.

Alarms and problems you may encounter during operating the UPS are given in the table below. If you have noticed an abnormality in operation; check the protective earth connections, examine the circuit breaker positions, read alarms from the ALARMS menu and refer to the table. Apply all suggestions corresponding to each alarm. If your issue is excluded or the suggested actions do not solve your problem, consult the technical service.

Alarm	Possible Cause	Action
BYP BAD alarm is present	Bypass mains voltage is different than the inverter reference signal	Make sure that the bypass circuit breaker is "I"/"ON"(if the UPS has no separate bypass mains input, make sure that the input circuit breaker is "I"/"ON".
	(e.g. its beyond its limits or it has a total harmonic distortion > %10)	
VBYP HIGH alarm is present	Bypass mains voltage is higher than its upper limit	Check if the bypass mains voltage is in specified limits
VBYP LOW alarm is present	Bypass mains voltage is lower higher than its lower limit	
BYP SYN FL alarm is present	Frequency of bypass mains voltage is beyond the frequency range for bypass operation or bypass mains voltage is very low	
BYP SEQ FL alarm is present	Phase sequence of bypass mains voltages is not OK	Phase sequence of the separate bypass mains input shall be changed. Consult technical service
MAN BYP alarm is present	Manual bypass switch is "ON"	Check the position of the manual bypass switch.
INV OVTE alarm is present	Inverter block temperature is very high	Check if there is an overload and remove the excessive load. Measure the ambient temperature near UPS. Make sure that the temperature is in specified limits. Check if the fans are running.
OUT OVLD alarm is present	Rms current drawn from any of the output lines exceeds its nominal value	Check if there is an overload and remove the excessive load. If the total power drawn by the load is less than the nominal power, make sure that it is distributed evenly between phases.
INV BLKD alarm is present	Inverter operation is automatically stopped due to a fault	Consult the technical service

Alarm	Possible Cause	Action
VSEC NOK alarm is present (Output voltage is beyond its limits)	The UPS may not started up yet. This alarm is permanent if the UPS is intended to be started with the bypass blocked or when the bypass mains is not in specified limits	<p>Make sure that all circuit breakers is "I"/"ON"</p> <p>Check if there is any other alarms and apply the related suggestions</p> <p>Examine the preferences, check the mains voltages and read the "modes of operation" section of the manual. Determine if the combination of line voltages and preferences does inhibit the UPS operation.</p>
	The UPS may have stopped to feed the load because the combination of the mains conditions ant the user preferences made from the COMMANDS menu does not allow the UPS to work in any of the operation modes.(e.g. if inverter is disabled and both input and bypass mains voltages are not acceptable or if the rectifier is disabled when the bypass voltage is not in specified limits or batteries may be discharged during a prolonged outage)	
	The output circuit breaker is "0"/"OFF"	
VIN HIGH alarm is present	Input line/neutral voltage is higher than its upper limit	Check if the bypass mains voltage is in specified limits
VIN LOW alarm is present	Input line/neutral voltage is lower than its lower limit	
IN SYN FLR alarm is present	Frequency of mains voltage is beyond the frequency range for normal operation or mains voltage is very low	Check if the mains voltage is in specified limits
IN SEQ FLR alarm is present	Phase sequence of input mains voltages is not OK	Phase sequence of the mains input shall be changed. Consult technical service
RECT OVTE alarm is present	Rectifier block temperature is very high	<p>Measure the ambient temperature near UPS. Make sure that the temperature is in specified limits.</p> <p>Check if the fans are running.</p>
RECT OVLD alarm is present	RMS current drawn from any of the input lines exceeds its nominal value	Check if there is an overload and remove the excessive load.
VDC HIGH alarm is present	Any of the DC bus voltages is higher than its upper limit	Consult the technical service
VDC LOW alarm is present	Any of the DC bus voltages is lower than its lower limit Means that the batteries had discharged. It is removed when the rectifier resets.	If you encounter this alarm during start-up, check if the inrush circuit breaker is "ON"/"I".
		Charge the batteries, perform battery test and check if the alarm has removed.
RECT BLKD alarm is present	Rectifier operation is automatically stopped due to a fault	Consult the technical service

Alarm	Possible Cause	Action
VDC NOK alarm is present	Any of the DC bus voltages approaches its lower or upper limits May mean that the batteries have approached to their lower voltage limit and are almost empty.	Charge the batteries, and check if the alarm has removed.
AMB OVTE alarm is present	Ambient temperature exceeds its upper limit	Measure the ambient temperature near UPS. Make sure that the temperature is in specified limits.
GEN ON alarm is present	Generator friendly operation is activated (digital input "GEN ON" is set high)	Check the "GEN ON" input
UPS OFF alarm is present	Emergency stop is activated (digital input "UPS OFF" is set high)	Check the "UPS OFF" input
BATT FAILED alarm is present	Batteries failed in the battery test	Perform the test again when the batteries have been charged for a long time and the battery circuit breaker is "I"/"ON" Check if the alarm continues
BATT C. OPEN alarm is present (A difference between battery & DC bus voltage is present)	Battery circuit breaker (F5) is probably open ("0"/"OFF")	Make sure that the battery circuit breaker is "I"/"ON". If not do the following: -Check the rectifier preference and enable the rectifier. -Make sure that the input mains voltage is in specified limits. -Make sure that the UPS has switched to normal mode and close the battery circuit breaker.
	The battery circuit breaker of the external battery cabinet is open ("0"/"OFF")	Make sure that the battery circuit breaker of the external battery cabinet is "I"/"ON". If not do the following: -Check the rectifier preference and enable the rectifier. -Make sure that the input mains voltage is in specified limits. -Make sure that the UPS has switched to normal mode and close the battery circuit breaker.
	Battery fuses of the battery circuit breaker (F5) or the external battery cabinet may have blown	Check if the battery fuses are blown. Replace if necessary (see maintenance section)
	There is no battery in the system	Batteries shall be supplemented. Consult technical service

10 Technical Specifications

MODELS												
Apparent power [kVA]	10											
ENVIRONMENTAL												
Storage temperature range [°C]	-25 to +55 (15 - 40 recommended for longer battery life)											
Operating temperature range [°C]	0 to +40 (20 - 25 recommended for longer battery life)											
Relative humidity range	% 0 - % 95 (non condensing)											
Max. altitude without derating [m]	1000											
Protection level	IP 20											
Maximum power dissipation	[W]	800										
	[Btu]	2730										
	[kcal/h]	688										
ELECTRICAL												
Mains Input												
Number of phases	3P +PE											
Nominal voltage [V]	208 (line-line)											
Voltage range for normal operation (line to line) [V]	Lower limit (depends on the load level)	177 @ %100 load (line- line)										
		114 @ %64 load (line- line)										
		73V@ %42 load (line- line)										
	Upper limit	264 (line-line)										
Nominal frequency [Hz]	60											
Frequency range [Hz]	+/-10%											
Nominal current [A]	wave form	sinusoidal										
	rms value *(2)	30										
Maximum current [A]	wave form	Sinusoidal										
	rms value	30										
OUTPUT @ 3PH OUTPUT UPS												
Performance classification according to IEC 62040-3	VFI-SS-111											
Number of phases	3P+ PE											
Nominal voltage [V]	208 (line-line)											
Static voltage regulation @ %100 linear load	normal	<%1										
	battery											
Nominal frequency [Hz]	60											
Free running frequency [Hz]	± % 0.01											
Voltage THD @ rated linear load	<%3											
Nominal apparent power [kVA]	10											
Maximum load p. f.	0.8											
Nominal active power [kW]	8											
Nominal current [A] at 208V	30											
Load crest factor @ rated power	3:1											
Overload duration	>1min @ %150 load											
Efficiency (normal operation) @rated linear load with 0.8 PF	Up to 94% *											

STATIC BY-PASS LINE @ 3PH OUTPUT UPS												
Number of phases	3P+ PE											
Voltage range (line- line) [V]*(1)	170-220V											
Frequency range [Hz] *(1)	57-63											
Nominal apparent power [kVA]	10											
Nominal current [A]	30											
Transfer duration [ms]	0											
BATTERIES												
Battery type	Sealed lead acid, 12 V											
Number of batteries	2x17											
Nominal battery voltage [V]	2x204											
Stored energy time @ nominal load with internal batteries*(2)	7Ah	14m										
	9 Ah	25m										
STANDARDS												
Safety	EN 62040-1:2008											
Performance	EN 62040-3:2008											
EMC	EN 62040-2:2006											
Product Certification	CE											
COMMUNICATIONS												
Free contact communication (AC failure, battery under voltage, bypass and output failure)												
Serial communications (RS232, RS 422)												
Two digital inputs for remote shut down of the UPS and generator operation feedback												
Isolated auxiliary 5V supply for digital inputs												
OTHERS												
Manual by-pass with 0 transfer time												
Electronic short circuit protection												
Over temperature and over current protection												
Liquid crystal display (LCD)												
Mimic front panel												

*(1) These are software parameters. They can be changed upon request

*(2) Batteries shall be fully charged in order to provide these values

* this parameter may vary depending on ups power

 All the settings of this UPS are made for Canon, changing settings is not allowed.

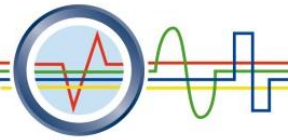

PROJECTS
wesemann