

9700 Series

UNINTERRUPTIBLE POWER
SUPPLY SYSTEMS



**Where Reliability
Breeds Confidence**

ISO 9001
CERTIFIED

 **mitsubishi electric**

Superior Performance, Reliability and Safety Come from Experience. Our Uninterruptible Power Supply Systems Ensure All Three.

Mitsubishi Electric has been developing and manufacturing Uninterruptible Power Supply (UPS) components and systems for more than three decades. That experience, and the continuous application of new power-device technologies to further improve products in the industry clearly explain why Mitsubishi Electric has dominated a large portion of the world UPS market for years.

When purchasing a UPS system, the key word is “dependability.” And there’s one company that many rely on. Uninterruptible Power Supply systems by Mitsubishi Electric.

IGBT - Transistors with Excellent Performance Characteristics

Mitsubishi Electric is the leading manufacturer of Insulated Gate Bipolar Transistors (IGBTs), and now utilizes IGBTs in the converters and inverters of its 9700 Series UPS systems. These advanced, high-performance transistors provide a variety of intelligent features.

- High Ampacity Transistors (600A)
- High Speed Switching
- Low Control Power

Low Input Current Harmonics (THD)

- 3% maximum (100% load)
 - 4% maximum (75% load)
 - 5% maximum (50% load)
- (No additional filtering required)

Input Power Factor

- 0.99 typical (0~100%)
- 1:1 Ratio (No oversizing of generator)

Benefit of Lower Input Current

- Smaller upstream components (Transformers, Circuit Breakers and cable sizing)

Low Heat Loss / High Efficiency

Use of IGBTs transistor enables efficient high-speed switching (6kHz), thus reducing heat dissipation in the UPS. (Higher efficiency means lower cost per kilowatt to the customer.)

ONE-LINE DIAGRAM

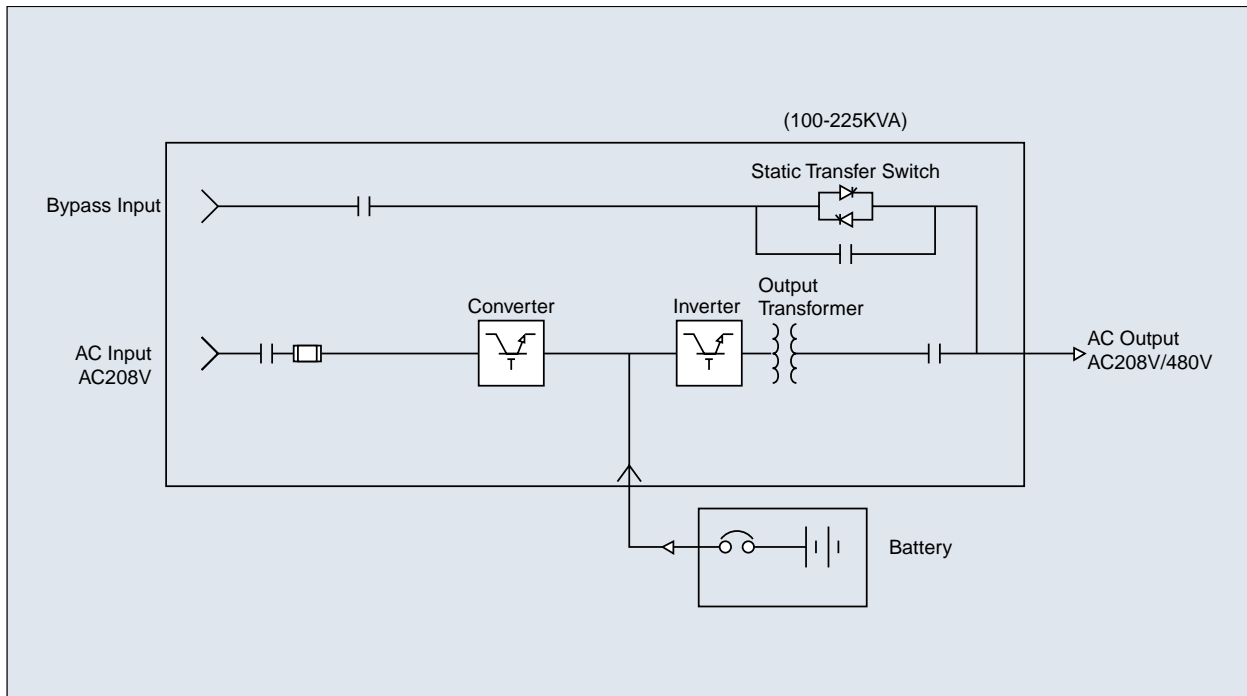

S O F T W A R E

What is DiamondLink™?

DiamondLink is user-customizable power monitoring, management and shutdown software, designed to provide information about the power condition of the UPS system.

How does DiamondLink work?

DiamondLink is designed to run on network server or workstations in any office environment. The software will monitor the status of your UPS and, when critical events occur, will perform a graceful unattended shutdown.

Features

- Automatic unattended shutdown
- Smart messages can be user-defined
- User-defined actions for a specific list of power-events
- Color coded power event logging
- Built-in graphing routines allow customized graphs to be created on-line
- DiamondLink can be used with all Mitsubishi single-phase and three-phase products

Specifics

- Power history graphs
- Custom user defined events
- Data log viewer
- E-mail configurations
- E-mail options for power events
- Event action
- Events log file
- Modem alert notification
- Pager notification
- Paging option

Supported Operating Systems

- Microsoft Windows®
- Microsoft Windows NT
- Microsoft Windows '95
- Microsoft Windows '00
- OS/2
- Novel NetWare®
- SVR4
- SCO UNIX

- SCO XENIX
- Solaris™
- IBM® AIX®-RS/6000™
- HP-UX
- SGI
- Digital UNIX
- Red Hat (LINUX)

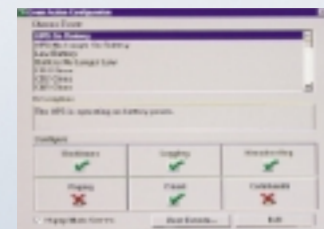

HING IS POSSIBLE

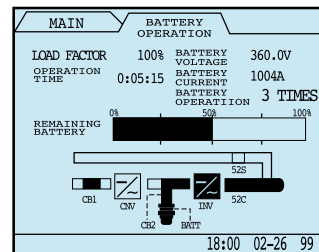
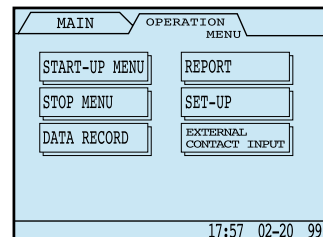
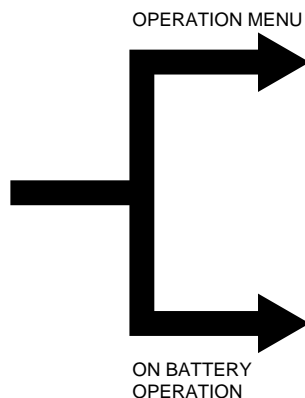

Extended Battery Life (0-100% Load Step)

- Supplemental current from the batteries is no longer required with the installation of IGBTs transistor in both the converter and inverter. Other UPS systems require assistance from the battery during step load conditions. The additional battery cycling results in decreased battery life.

Isolated Redundant System

- The 9700 Series is designed for isolated redundant applications.
- Lower cost to consumer, small footprint, less components.
- Different kVA sizes and different series can be used for greater flexibility of the overall system.

Operator-Friendly Control Panel

Features:

- Mimic bus diagram
- Operator's control station
- Touch panel input

LCD monitor displays:

- System metering
- Menu-driven start-up procedures
- Menu-driven operation procedures
- History of events
- Trend graph

Additional Features:

- Password locked for start / stop operation
- Sealed EPO button

Realtime Battery Monitoring

- Remaining time in battery charge displayed for operator
- Software algorithms continuously calculate and update actual remaining time in battery charge.

Superior Functions

- Automatic restart
- Automatic retransfer
- Converter walk-in function
- Battery monitoring
- Ripple-free DC output (rectifier)
- 1-set "Form A" dry contracts of selectable items
- Large overload / overcurrent capacity
- Battery temperature compensation
- Adjustable DC cut-off

Quiet Operation

- 100kVA → 63dB (A scale, 1m)
- 150 - 225kVA → 65dB (A scale, 1m)

Software

- RS-232C parallel interface
- Multiple server shutdown software (V. 1.50)
- DiamondLink application software
- 90% of all operating systems are compatible with DiamondLink
- Multilingual
- Paging, E-mail capability during power events
- Auto-dial
- Ethernet LAN connection interface (optional)
- SNMP Interface

Warranty

Standard warranty is two years, including parts and labor.

(NOTE: All information subject to change without prior notice.)

GSA Contract Number

GS-07F-9526G

SPECIFICATIONS

UPS Cabinets

kVA/KW	208 V / 208 V Dimensions (W x D x H) (in)	Weight (lbs)
100/80	35.4 x 29.9 x 79.7	2,400
150/120	47.2 x 29.9 x 79.7	2,900
225/180	55.1 x 29.9 x 79.7	3,630

NOTE: Batteries not included.



Battery Cabinets

Part Number	Quantity	Dimensions (W x D x H) (in)	Weight (lbs)	100	150	225
BC43-PH300-360	3	108 x 29.5 x 79.7	7,518	40 min	22 min	10 min
BC43-PH350-360	3	108 x 29.5 x 79.7	8,580	52 min	28 min	13 min
BC43-PH440-360	3	108 x 29.5 x 79.7	11,010	64 min	40 min	20 min
BC43-PH440-360	4	144 x 29.5 x 79.7	14,680	90 min	55 min	31 min

Above battery manufacturer: YUASA-Exide

Standard Features

- IGBTs transistor (converter/inverter)
- UL/cUL approved (1778)
- Hermetically sealed boards (industrial environment)
- Front access only (serviceability)

Battery DC Link

- 360 VDC

Operating Environment

- Low acoustic noise
- Temperature: 0~40°C
- Relative humidity: 5~95% (non-condensing)

AC Input Rating

- +10%~-15%
- 208 VAC
- THD: 3% max. (100% load)
- 3-phase, 3-wire, plus ground
- Frequency: 60Hz (±5%)
- Surge withstand: meets IEEE 587/ANSI C62.41
- Input THD: 3% max. (100% load)
5% max. (50% load)

AC Output Rating

- 3-phase, 4-wire
- Output power factor rating: 0.8
- Frequency: 60Hz
- Voltage accuracy: ±1%
- Transient recovery time: 20ms
- Load unbalance: 100% ±1% or less
- Step load change: 0~100% ±2%
- Load/Return of AC power: ±1%
- UPS load transfer, bypass: ±5%
- THD: 2% max. (100% linear load);
5% max. (100% nonlinear load)
- Slew rate: Adjustable
- Adjustable Output Voltage ±5%

9700 Series

UNINTERRUPTIBLE POWER SUPPLY SYSTEMS



Corporate Headquarters:

Mitsubishi Electric Automation, Inc.
500 Corporate Woods Parkway
Vernon Hills, IL 60061
Phn: (847) 478-2100
Fax: (847) 478-2253
www.meau.com



The quality management system of Mitsubishi Electric Corporation Kobe Works has been approved to ISO9001:1994.

The quality management system is applicable to design, development and manufacturing of the UPS.

L-VH-08203 Printed in USA
Effective February, 2001
Specifications and products offered
subject to change without notice.