

2033A Series

UNINTERRUPTIBLE POWER
SUPPLY SYSTEMS



**Where Reliability
Breeds Confidence**

ISO 9001
CERTIFIED

 **MITSUBISHI ELECTRIC**

Superior Performance, Reliability and Safety Come from Experience. Our Uninterruptible Power Supply Systems Ensure All Three.

Mitsubishi Electric has been developing and manufacturing Uninterruptible Power Supply (UPS) components and systems for more than three decades. That experience, and the continuous application of new power-device technologies to further improve products in the industry clearly explain why Mitsubishi Electric has dominated a large portion of the world UPS market for years.

When purchasing a UPS system, the key word is “dependability.” And there’s one company that many rely on. Uninterruptible Power Supply systems by Mitsubishi Electric.



Intelligent Power Module (IPM) Transistors with Excellent Performance Characteristics

Mitsubishi Electric is the leading manufacturer of Intelligent Power Modules (IPMs), and now utilizes Intelligent Power Module transistors in the converters and inverters of its 2033A Series UPS systems. These advanced, high-performance transistors provide a variety of intelligent features.

- Drive Circuitry
- Overcurrent Protection
- Over Temperature Protection
- Control Voltage Drop Protection
- Short-Circuit Protection

Low Input Current Harmonics (THD)

- 3% maximum (100% load)
 - 4% maximum (75% load)
 - 6% maximum (50% load)
- (No additional filtering required)

Input Power Factor

- 1:1 ratio (UPS kVA/Generator kW)

Low Heat Loss/High Efficiency

Use of Intelligent Power Module transistors enables efficient high-speed switching (6kHz), thus reducing heat dissipation in the UPS. (Higher efficiency means lower cost per kilowatt to the customer.)

ONE-LINE DIAGRAM

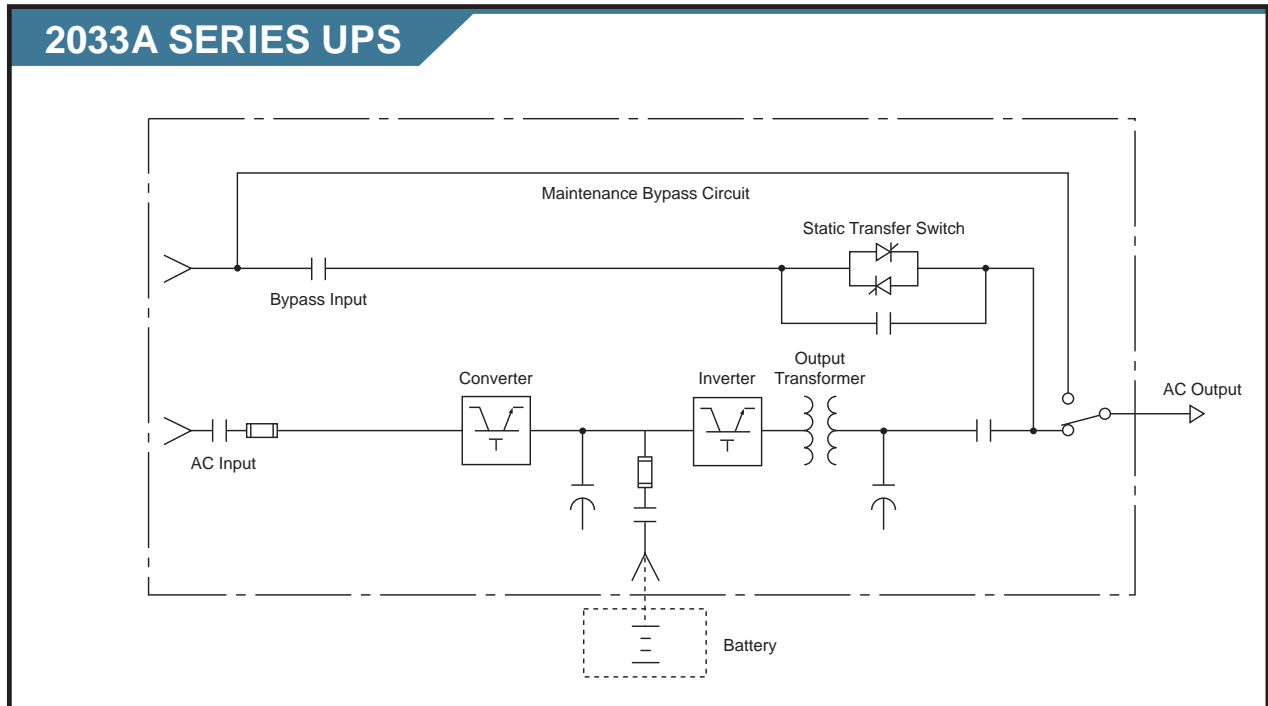

S O F T W A R E

What is DiamondLink™?

DiamondLink is user-customizable power monitoring, management and shutdown software, designed to provide information about the power condition of the UPS system.

How does DiamondLink work?

DiamondLink is designed to run on network server or workstations in any office environment. The software will monitor the status of your UPS and, when critical events occur, will perform a graceful unattended shutdown.

Features

- Automatic unattended shutdown
- Smart messages can be user-defined
- User-defined actions for a specific list of power-events
- Color coded power event logging
- Built-in graphing routines allow customized graphs to be created on-line
- DiamondLink can be used with all Mitsubishi single-phase and three-phase products

Specifics

- Power history graphs
- Custom user defined events
- Data log viewer
- E-mail configurations
- E-mail options for power events
- Event action
- Events log file
- Modem alert notification
- Pager notification
- Paging option

Supported Operating Systems

- Microsoft Windows®
- Microsoft Windows NT
- Microsoft Windows '95
- Microsoft Windows '98
- Microsoft Windows '00
- OS/2
- Novel NetWare®
- SVR4
- SCO UNIX
- SCO XENIX
- Solaris™
- IBM® AIX®-RS/6000™
- HP-UX
- SGI
- Digital UNIX
- Red Hat (LINUX)



HING IS POSSIBLE

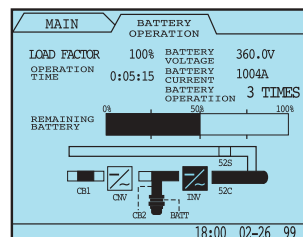
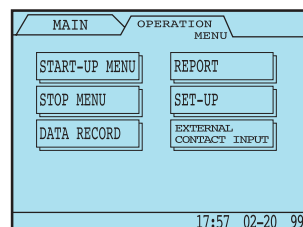
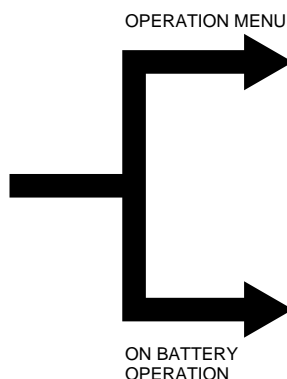
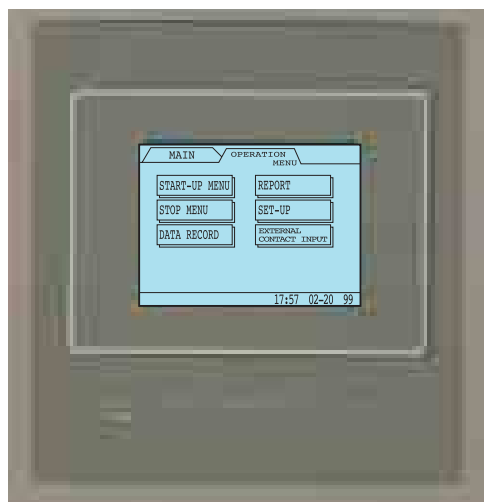

Extended Battery Life

- Current source from batteries for step loads is no longer required with the installation of Intelligent Power Module transistors in both the converter and the inverter. Previous UPS systems required assistance from batteries when the converter was unable to supply the required current. This cycling of batteries caused shorter life.
- Mitsubishi Electric Intelligent Power Modules incorporate the latest technologies and provide step load applications (0-100%) without the use of batteries, thus ensuring maximum battery service life (i.e., lower lifetime cost of UPS system).

Internal Maintenance Bypass

- All 2033A Series UPS systems are equipped with an internal wrap around maintenance bypass system for greater maintenance flexibility.
- UL 1778 approved

Superior Control

All 2033A Series UPS systems use pulse width modulation (PWM) for superior control and performance. A digital signal

processor (DSP) ensures precise control of all input/output parameters.

Operator-Friendly Control Panel

Features:

- Mimic bus diagram
- Operator control station
- Touch panel input

LCD Monitor Displays:

- System metering
- Menu-driven start-up procedures
- Menu-driven operating procedures
- History of events
- Trend graph
- Load true power factor

Additional Features:

- Password lock out for start/stop operation
- EPO button

Real-Time Battery Monitoring

- Remaining battery time displayed for operator
- Integrated "DiamondSense" system automatically detects weak cells

Superior Functions

- Automatic restart
- Automatic retransfer
- Converter walk-in function
- Battery monitoring

- Ripple-free DC output (converter)
- 1 set "Form A" dry contacts of selectable items
- Large overload/overcurrent capacity
- Battery temperature compensation
- Adjustable DC cut-off

Quiet Operation

- 30-50kVA→60dB (A scale, 1m)
- 75kVA→65dB (A scale, 1m)

Software

- RS232C serial interface
- DiamondLink application software
- 90% of all operating systems are compatible with DiamondLink
- Multilingual
- Paging, E-mail capability during power events
- Auto-dial
- Multiple server shutdown capabilities

Warranty

Standard warranty is two years, including parts and labor.

(NOTE: All information subject to change without prior notice.)

GSA Contract Number

GS-07F-9526G

SPECIFICATIONS

UPS Cabinets

kVA	208 V / 208 V Dimensions (W×D×H) (in)	Weight (lbs)	480 V / 480 V Dimensions (W×D×H) (in)	Weight (lbs)
30	35.4 × 29.5 × 70.9	1,050	59.4 × 29.5 × 70.9	2,250
40	43.3 × 29.5 × 70.9	1,480	67.3 × 29.5 × 70.9	2,680
50	43.3 × 29.5 × 70.9	1,500	67.3 × 29.5 × 70.9	2,850
75	43.3 × 29.5 × 70.9	1,700	67.3 × 29.5 × 70.9	3,160

- NOTES: 1) All 2033A Series UPS Systems include a "zero energy" maintenance bypass.
 2) Dimensions of 30kVA 480 V input/208 V output UPS systems are 16" wider than 208 V/208 V systems.
 3) Dimensions of 40kVA through 75kVA 480 V input/208 V output UPS systems are 24" wider than 208 V/208 V systems.
 4) All dimensions of 600 V input/600 V output are the same as 480 V/480 V systems.
 5) Batteries not included.

Battery Cabinets

Part Number	Dimensions (W×D×H) (in)	Weight (lbs)	Back-Up Time in Minutes			
			30kVA	40kVA	50kVA	75kVA
BC39-12100-30-360	36 × 29.5 × 70.9	1,050	7	—	—	—
BC39-12140-30-360	36 × 29.5 × 70.9	1,230	12	8	5	—
BC39-12170-30-360	36 × 29.5 × 70.9	1,620	15	9	7	—
BC39-12270-30-360	36 × 29.5 × 70.9	2,130	32	22	15	8
BC39-12310-30-360	36 × 29.5 × 70.9	2,430	40	25	17	10
BC39-12370-30-360	36 × 29.5 × 70.9	2,640	—	—	—	12

NOTE: Additional battery configurations available upon request.

Standard Features

- IPM transistors (converter/ inverter)
- UL/cUL approved (1778)
- Zero energy MBS
- Conformal coated boards (industrial environment)
- Front access (serviceability)

Battery DC Link

- 360 VDC

Operating Environment

- Low acoustic noise
- Temperature: 0~40°C
- Relative humidity: 5~95% (non-condensing)
- Altitude: 9,000 ft

AC Input Rating

- +10%~ -15%
- Power: Rated kVA at 1:1 ratio
- 208/480/600 VAC
- THD: 3% max. (100% load)
6% max. (50% load)
- 3-phase, 3-wire, plus ground
- Frequency: 60Hz (±5%)
- Surge withstand: Meets IEEE 587/ANSI C62.41

AC Output Rating

- 3-phase, 4-wire
- 208/480/600 VAC
- Frequency: 60Hz
- Voltage accuracy: ±1%
- Transient recovery time: 1 cycle
- Load unbalance: 100% ±1% or less
- Step load change: 0~100% ±3%
- Load/Return of AC power: ±1%
- UPS load transfer, bypass: ±3%
- THD: 2% max. (100% linear load); 4% max. (100% nonlinear load)
- Slew rate: Adjustable

2033A Series

UNINTERRUPTIBLE POWER SUPPLY SYSTEMS



Corporate Headquarters:

Mitsubishi Electric Automation, Inc.
500 Corporate Woods Parkway
Vernon Hills, IL 60061
Phn: (847) 478-2100
Fax: (847) 478-2253
www.meau.com



The quality management system of
Mitsubishi Electric Corporation Kobe Works
has been approved to ISO9001:1994.

The quality management system is
applicable to design, development and
manufacturing of the UPS.

L-VH-08152 Printed in USA
Effective March, 2003
Specifications and products offered
subject to change without notice.